

Internal tank cleaner with electric drive

- Cleaning head R55
- 360° spray coverage
- Variable shaft lengths
- Electric drive
- Variable speed
- maximum 250 bar
- Maximum 50 liters/minute
- Installation opening > ø60 mm
- INOX 1.4301 / VITON



General description



The ER55.STD tank cleaner consists of a cleaning head, an electric drive and a connecting pipe. The container cleaner is designed in such a way that the spray head is set in rotation by the drive motor. There is a gearing on the spray head which engages with a fixed gearing on the connecting pipe. This sets the spray head itself into an additional rotational movement offset by 90°. Due to the rotation in two axes, the nozzles rotate in a spherical shape, whereby all areas in the container are hit once by the water spray after a certain time.

This modular design means that the individual elements can be replaced and quickly put back into operation if servicing is required.

Product features

- Functionality**
 - Rotation of cleaning head and cleaning nozzles achieves 360° spray coverage
- Adjustability**
 - The drive is available in different speeds
 - Container cleaner can be used for different container sizes thanks to pipe extension
- Functional safety**
 - Designed for durability and easy maintenance
 - Very low operating noise

Variants

- Drive:**
 - Speed**
 - 11.9, 15.2, 22 rpm
 - Tension**
 - 115V AC 60Hz, 230V AC 50Hz, 24V AC
 - Hood**
 - Plastic, stainless steel
 - Switches**
 - With switch, without switch
 - Cable gland**
 - Rear, lateral
- Connecting tube:**
 - Length**
 - 500, 700, 1000, 1500, 2000, 3000, 4000mm, other lengths only on request

Technical data

Drive	electric	See section Variants
Hydraulic data	Minimum pressure	100 bar
	Maximum pressure	250 bar
	Minimum flow rate	10 l/min
	Maximum flow rate	50 l/min
	Spray cover	360°
	Maximum temperature	120 °C
	Connection	M22x1.5 / G1/2" / G3/8"
Nozzles		2 pieces
		0° / 5° / 15°
		1/8"
Mechanical data	Speed	11.9 / 15.2 / 22 revolutions/minute
	Cycle complete	Depending on the speed and soiling
Material	Cleaning head	1.4301 INOX
	Connecting tube	1.4301 INOX
	Motor	PA6, black / 1.4301 INOX
	Seals	FPM Viton / EPDM / FDA
Installation data	Installation opening	larger Ø60 mm
		larger than Ø75 mm Automatic retraction/extension

Safety instructions

- This container interior cleaner is exclusively suitable for cleaning the interior of production, storage and transport containers that can be treated with a high-pressure water spray with cleaning solution.
- The appliance is only intended for use with fresh water and cleaning agents expressly approved by the manufacturer (see www.moog.ch). Always observe the operating conditions and performance limits specified in the technical data sheet.
- This appliance is a technical tool and is not intended for private use. Proper transportation and storage are also prerequisites for its intended use.

Installation instructions

Maintenance Clean the nozzles with compressed air or with a very thin metal rod if they are clogged with dirt. If necessary, replace the nozzles with similar nozzles with identical nozzle openings.

The filter screen in the inlet of the water-hydraulic drive must be cleaned regularly depending on the degree of soiling of the cleaning medium. A damaged filter screen must be replaced.

On delivery, the speed of the drive is adapted to the output of the high-pressure supply used according to customer requirements. This can be changed using the three flow control nozzles.

The maintenance intervals vary depending on the duration of use, pressure range, media temperature and cleaning agent used. These must be determined individually during trial operation. The operator is responsible for adhering to the maintenance intervals.

Maintenance must be carried out approximately every 300 operating hours and all seals must be replaced.

The ball bearings must be replaced with original bearings after 2000 operating hours at the latest.

Components

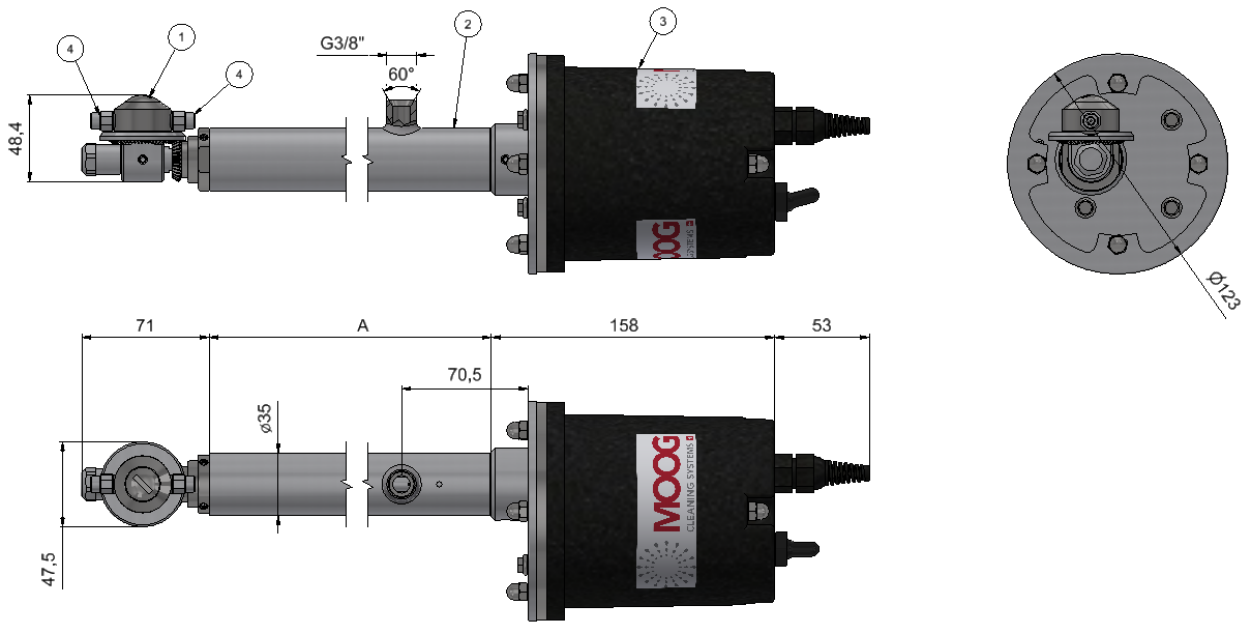

Positions	
Pos.	Component
1	Spray head combination S-R-55
2	Connecting tube $\varnothing 35$ mm
3	Electric drive
4	Nozzles

Length / longuer / length			
No.	A	No.	A
ER-55-0500	500mm	ER-55-1500	1500mm
ER-55-0700	700mm	ER-55-2000	2000mm
ER-55-1000	1000mm	ER-55-3000	3000mm
ER-55-2000	2000mm	ER-55-4000	4000mm

Accessories and spare parts

Accessories and spare parts Contact Sales +41 31 838 19 19
 info@moog.ch

Documentations

- Further documentation
- Operating instructions
 - Spare parts overview
 - Spare parts price list
 - Certificates
 - Declaration of conformity